

Swing Check Valve 90 Non-Return Valve

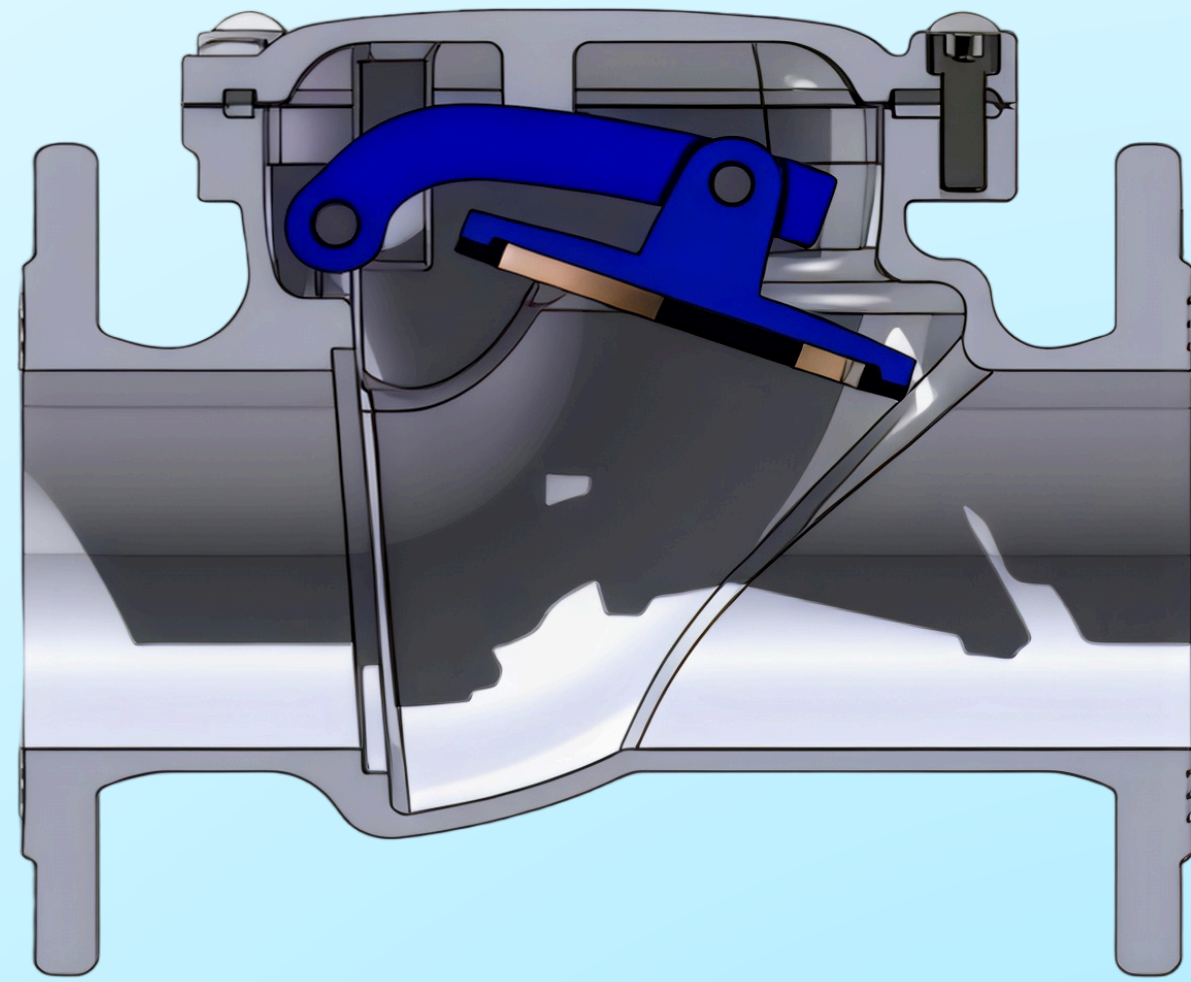

available both metal and resilient seats. Installed in pumping applications to prevent back flow, open and close automatically. It can be used for drinking water, waste water and air flow media. The check valve can be fitted to both vertical and horizontal pipelines. All interior parts are stainless steel or coated with drinking water approved epoxy or EPDM.



Standards

- ✓ **Designed to EN1074-3.**
- ✓ **Face to face length: EN 558 Table 2 Basic Series 48.**
- ✓ **Hydraulic tests according to EN 12266.**
- ✓ **Flange drilling to EN1092-2/BS4504, PN10/16.**
- ✓ **Working Temperature: -10°C to 80°C.**



Service Fields

- ✓ **Potable, Neutral liquid and raw water.**
- ✓ **Firefighting systems.**
- ✓ **Irrigation.**
- ✓ **Power plants and process industry.**

MAIN FEATURES

- ✓ Metal seat available materials of Brass, Bronze, Stainless steel.
- ✓ Rubber seat with EPDM rubber coated disc.
- ✓ Removable bonnet for easy maintenance.
- ✓ All seals and coatings contact to the fluid are approved for drinking water.
- ✓ Low headloss, compact design, simply maintenance.
- ✓ Opening on low differential pressure.
- ✓ Bonnet gasket in a groove between bonnet and body to prevent blow-out.
- ✓ 100% testing before packing and delivery.
- ✓ Designed to be installed horizontally.
- ✓ Vertical installation available if with upward flow medium.
-

PART LIST & Dimensions

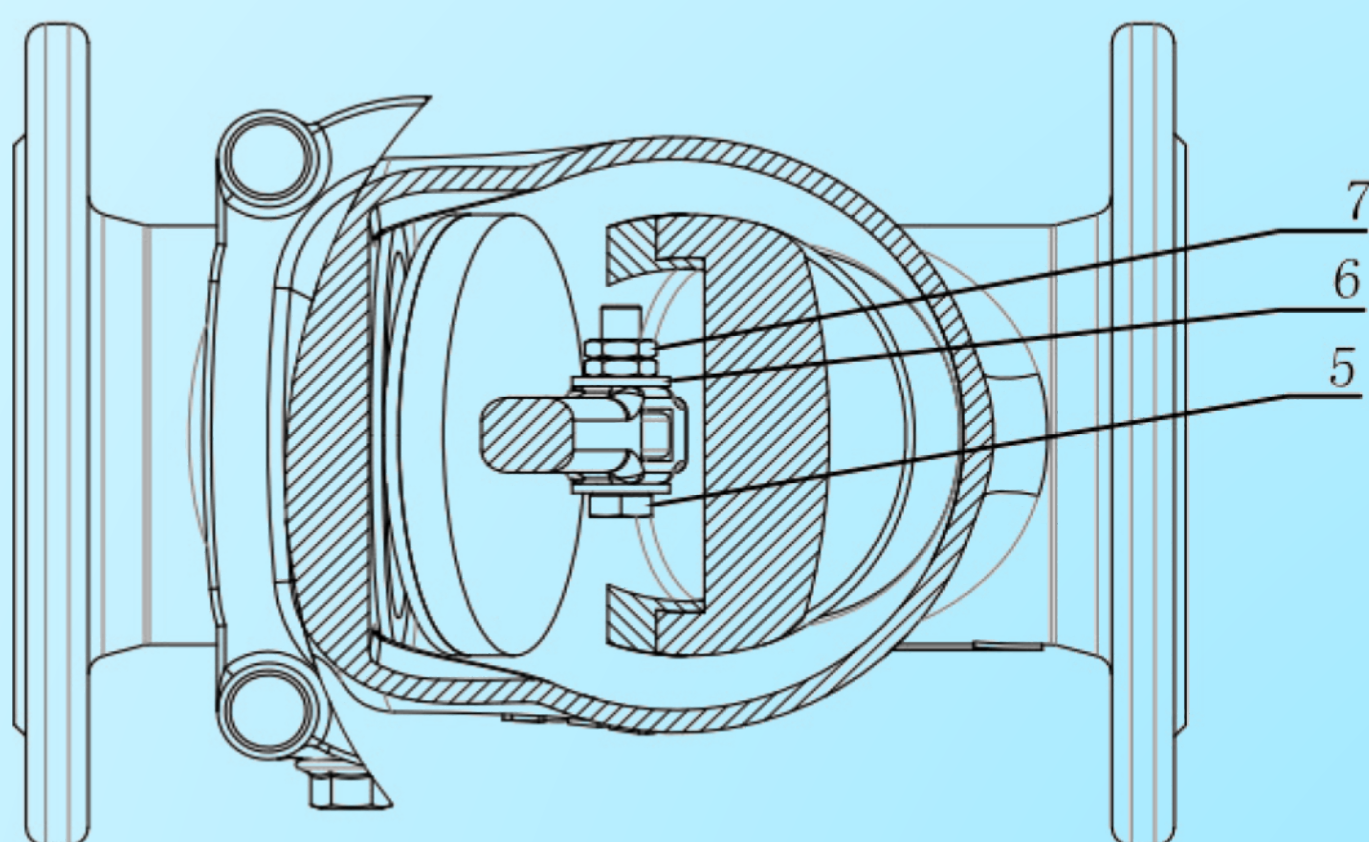
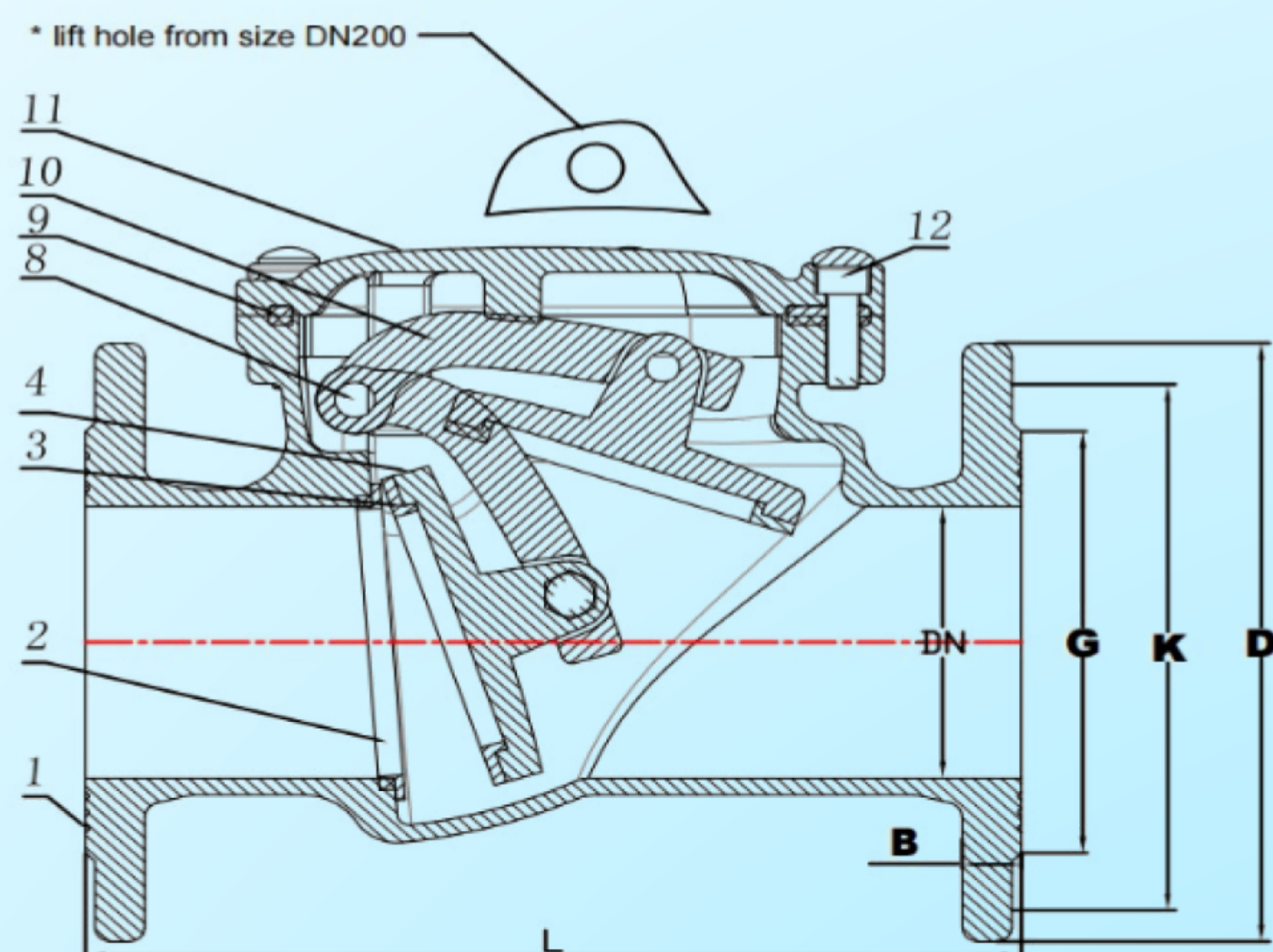

No.	Component	Standard Material
1	Body	Ductile iron GGG50
2	Body Ring	DI coated / Brass / Bronze / SS
3	Seal Ring	EPDM / Brass / Bronze / SS
4	Disc	Ductile iron GGG50
5	Disc fasten Bolt	Stainless steel
6	Gasket	NBR/EPDM
7	Disc Nut	Stainless steel 201
8	Disc Pin	Stainless steel 420
9	Cover Gasket	NBR/EPDM
10	Rocker Arm	Ductile iron GGG50
11	Cover	Ductile iron GGG50
12	Cover Bolt	Carbon steel / Stainless steel

- Type Rubber seat
Disk Ring: EPDM/NBR rubber
Body Ring: Ductile iron with epoxy coated surface
- Type Metal seat
Disk Ring: Brass/Bronze/SS
Body Ring: Brass/Bronze/SS

Nominal DN	OUTLINE mm			Flange Dimension (EN1092-2 / BS4504) PN10			
	Face to face (L)		B	D	K	G	n*d
BS5153	DIN-F6						
50	203	200	19	165	125	99	4*19
65	216	240	19	185	145	118	4*19
80	241	260	19	200	160	132	8*19
100	292	300	19	220	180	156	8*19
125	330	350	19	250	210	184	8*19
150	356	400	19	285	240	211	8*23
200	495	500	20	340	295	266	8*23
250	622	600	22	405	350	319	12*23
300	698	700	24.5	460	400	370	12*23
350	787	800	26.5	520	460	429	16*23
400	914	900	28	580	515	480	16*28
450	965	1000	30	640	565	530	20*28
500	1067	1100	31.5	715	620	582	20*28
600	1219	1300	36	840	725	682	20*31

Nominal DN	OUTLINE mm			Flange Dimension (EN1092-2 / BS4504) PN16			
	Face to face (L)		B	D	K	G	n*d
BS5153	DIN-F6						
50	203	200	19	165	125	99	4*19
65	216	240	19	185	145	118	4*19
80	241	260	19	200	160	132	8*19
100	292	300	19	220	180	156	8*19
125	330	350	19	250	210	184	8*19
150	356	400	19	285	240	211	8*23
200	495	500	20	340	295	266	12*23
250	622	600	22	405	355	319	12*28
300	698	700	24.5	460	410	370	12*28
350	787	800	26.5	520	470	429	16*28
400	914	900	28	580	525	480	16*31
450	965	1000	30	640	585	548	20*31
500	1067	1100	31.5	715	650	609	20*34
600	1219	1300	36	840	770	720	20*37





Thank You

 More Information
www.johntekvalve.com

 Our Email Address
info@johnlekvalve.com