

# Non-Return Nozzle check valve

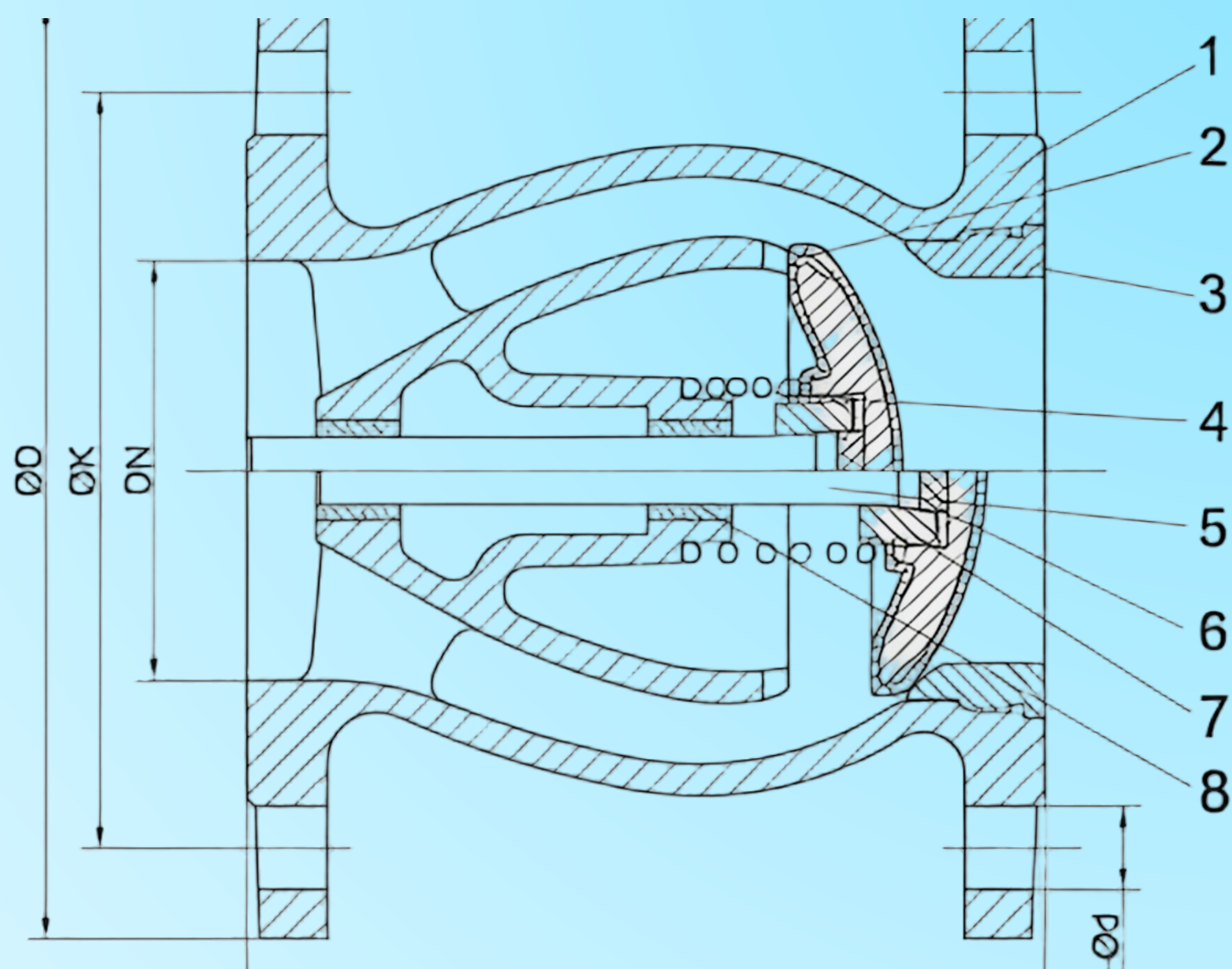

- ✓ BS EN1074-3/85 EN12334
- ✓ Range: DN50–DN300
- ✓ Working pressure: PN10 / PN16 / PN25
- ✓ Temperature range: 0°C–80°C
- ✓ Fusion bonded epoxy coating

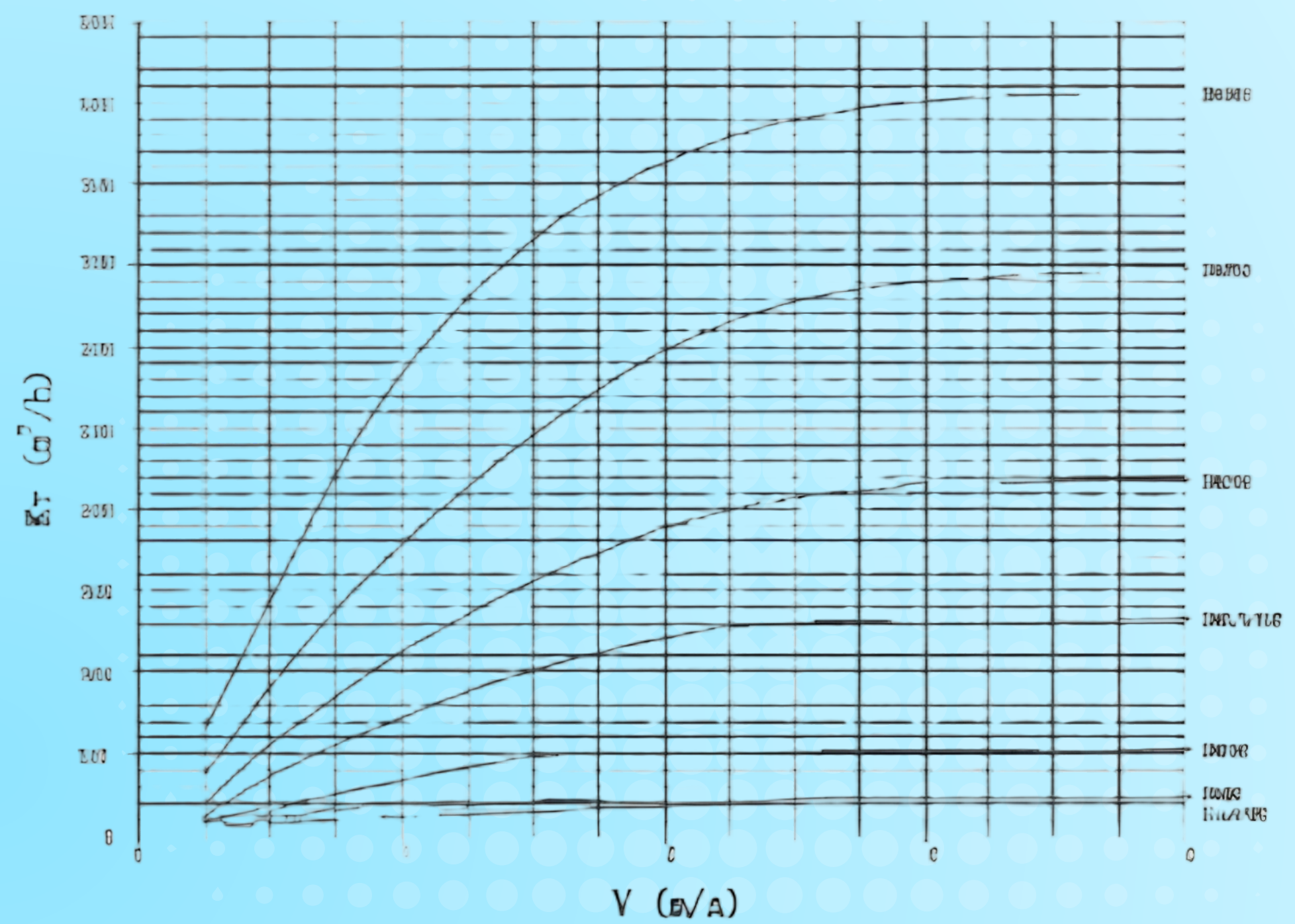

No.	Component	Standard Material
1	Body	Ductile iron
2	Ball	NBR
3	O-Ring	NBR
4	Cover	Ductile iron
5	Gasket	SS304
6	Washer	SS304
7	Nut	SS304

DN	50	65	80	100	125	150	200	250	300
Face to face(L)	150	150	180	190	210	210	230	250	270
Outer diameter of flange 7005-2	PN10	165	185	200	220	250	285	340	455
	PN16	165	185	200	220	250	285	340	455
	PN25	165	185	200	235	270	300	360	485
Weight of PN16(kg.) approx.	7	8	12	15	20	25	41	59	80
Shell test	37.5Bar								
Seat test	0.5 Bar & 27.5 Bar								



**Thank You**

 More Information  
[www.johntekvalve.com](http://www.johntekvalve.com)

 Our Email Address  
[info@johnlekvalve.com](mailto:info@johnlekvalve.com)