

# DOUBLE DISC WAFER SWING CHECK VALVE PN16; CLASS125/150



## Working conditions

- ✓ Fresh water, sea water
- ✓ Waste water
- ✓ Food stuff
- ✓ Steam
- ✓ Oil
- ✓ Weak acid & alkaline liquids etc.



## Service Fields

- ✓ Fresh water, sea water
- ✓ Waste water
- ✓ Food stuff
- ✓ Steam
- ✓ Oil
- ✓ Weak acid & alkaline liquids etc.

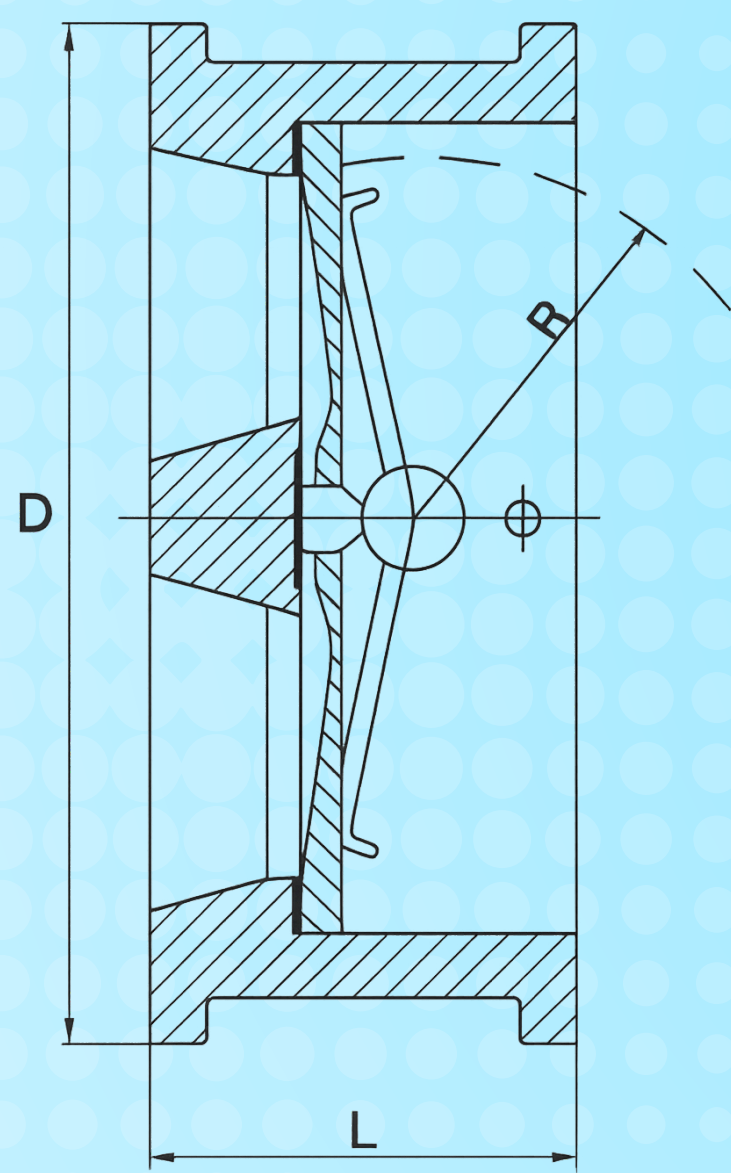

No.	Component	Standard
1	BODY	CAST IRON
		DUCTILE IRON
		STAINLESS
2	DISC	STEEL
		STAINLESS
		AL BRONZE CARBON
3	SEAT GASKET	RUBBER
4	AXLE	STAINLESS
5	SPRING	STAINLESS
6	WASHER	TEFLON



Nominal Diameter	D			L(EN558-1)		R
	DIN2501	TABLE D/E	ANSI 125/250	SERIES16	SERIES50	
50	107	96	4-1/8"	43	54(2-1/8")	28.8
65	127	109	4-7/8"	46	54(2-1/8")	36.1
80	142	128	5-3/8"	64	57(2-1/4")	43.4
100	162	160	6-7/8"	64	64(2-1/2")	52.8
125	192	191	7-3/4"	70	70(2-3/4")	65.7
150	218	217/213	8-3/4"	76	76(3")	78.6
200	273	274/270	11"	89	95(3-3/4")	104.4
250	328/329	333/333	13-3/8"	114	108(4-1/4")	127
300	378/384	384/381	16-1/8"	114	143(5-5/8")	147
350	438/446	445	17-3/4"	127	184(7-1/4")	172.4
400	489/498	496	20-1/4"	140	191(7-9/16")	197.4
450	532/550	555	21-5/8"	152	203(8")	217.8
500	585/610	610	23-7/8"	152	213(8-3/8")	241
600	690/720	720	28-1/4"	178	222(8-3/4")	295.4
700		784/820			229	338.5
800		910/936			241	386.5
900		1011			241	455.5
1000		1128			300	495.5



**Thank You**

 More Information  
[www.johntekvalve.com](http://www.johntekvalve.com)

 Our Email Address  
[info@johnlekvalve.com](mailto:info@johnlekvalve.com)