

Lift Check Valve with SS screen

Foot Valves are specifically designed to be installed on the suction side of a pump. The purpose of a foot valve is to maintain pump prime between pumping cycles. Design of the Foot Valve evolved through a need for a valve that could provide positive sealing action at various pressure ranges without seal damage along with silent operation. The Foot Valve satisfies these requirements plus low head loss thru its full ported area and heavy duty stainless steel basket screening. The unique seating design provides initial contact with the valve disc and the ring, providing a drop-tight seal. As the pressure increases, the ring is compressed slightly and the disc makes contact with the metal portion of the valve seat, preventing any further compression of the ring. The ring will continue to provide the "drop-tight seating" during the higher pressure ranges without damage from the increased pressure loading.



MAIN FEATURES

- ✓ Full flow area - Unrestricted flow through the valve that is equal to or greater than the pipe size.
- ✓ designed to minimize headloss and optimize pumping efficiency.
flow areas 3 to 4 times larger than the nominal size of the valve to ensure pump efficiency and minimize headloss.
- ✓ fully guided disc: eliminating turbulence and vibrations and ensuring long service life.
- ✓ dynamic driptight sealing arrangement.
- ✓ 100% testing before packing and delivery.
- ✓ Completely free and full bore self-cleaning & low-pressure loss.
- ✓ Low inlet resistance due to streamlined configuration.
- ✓ Epoxy coating: WRAS approved for drinking water.

Standards

- ✓ Hydraulic tests according to EN-12266-1
- ✓ Flanges to EN-1092-2, BS4504

Service Fields

- ✓ Pumping stations.
- ✓ networks for clean water distribution.
- ✓ irrigation and water treatment.

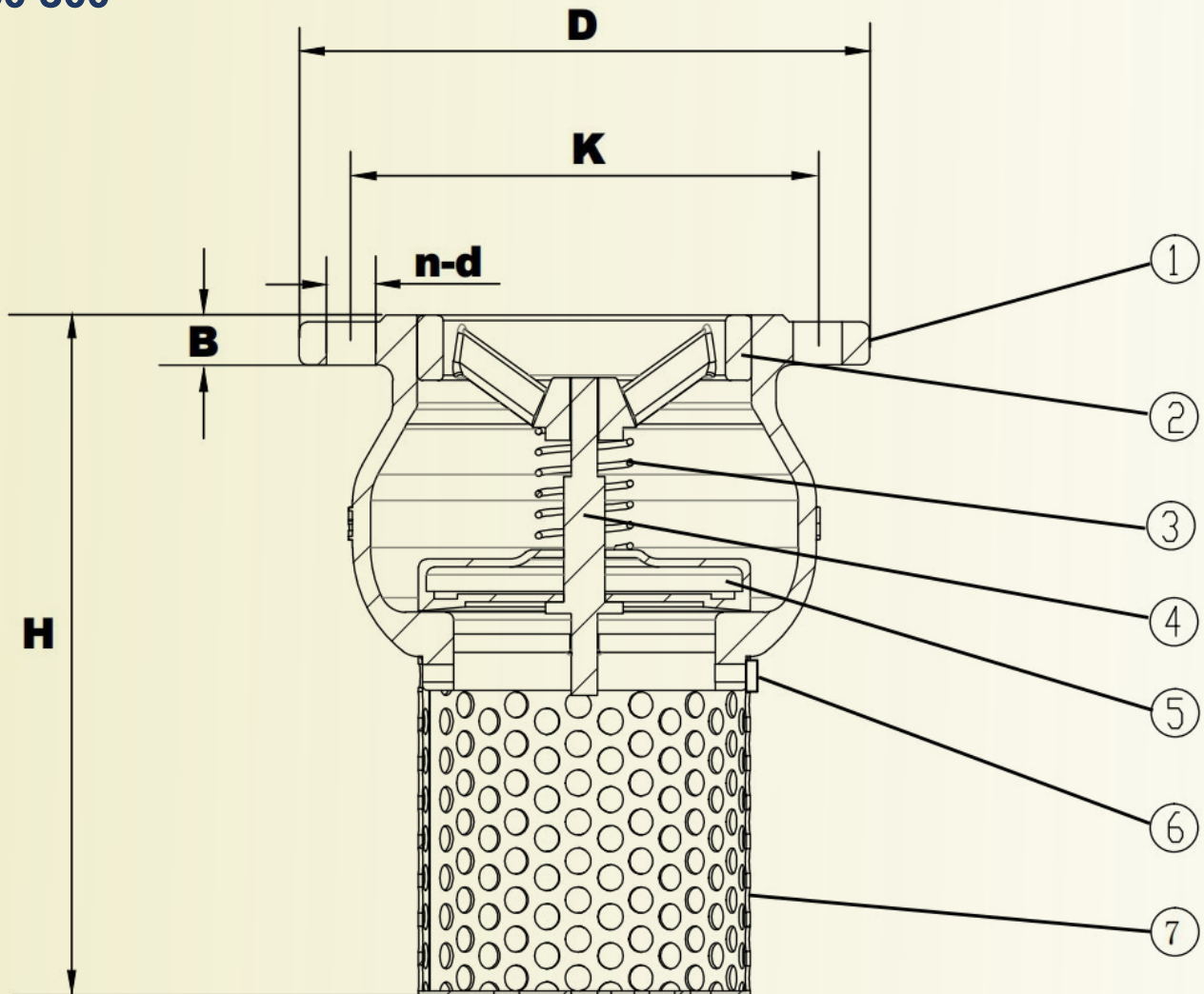
Part List
DN50-300

No.	Component	Standard Material
1	Body	Ductile Iron GJS500-7
2	Seat	Ductile Iron GJS500-7
3	Spring	SS AISI304
4	Stem	SS AISI 304/316/420
5	Disc	Ductile iron coated with EPDM
6	Bolt	SS AISI304
7	Screen	SS AISI304

Main Outline Dimensions DN50-300

Nominal Diameter	PN10				
	DN	ϕD	ϕK	B	H
DN50	165	125	19	190	4*19
DN65	185	145	19	210	4*19
DN80	200	160	19	240	8*19
DN100	220	180	19	250	8*19
DN125	250	210	19	310	8*19
DN150	285	240	19	370	8*23
DN200	340	295	20	450	8*23
DN250	405	355	22	470	12*23
DN300	460	410	25	500	12*23

Nominal Diameter	PN16				
	DN	ϕD	ϕK	B	H
DN50	165	125	19	190	4*19
DN65	185	145	19	210	4*19
DN80	200	160	19	240	8*19
DN100	220	180	19	250	8*19
DN125	250	210	19	310	8*19
DN150	285	240	19	370	8*23
DN200	340	295	20	450	12*23
DN250	405	355	22	470	12*28
DN300	460	410	25	500	12*28