

Dismantling Joint



Provides easy installation and disassembly of flanged equipment, Corrosion resistant construction, Studs are located on every flange hole, Tie rods are required from the upstream to downstream sides of the pipe equipment installation, Suitable for portable water, neutral liquids and sewage.

Working conditions

- ✓ Water temperature:
Maximum temperature: -10°C to +70°C.
- ✓ Water pressure: PN10/16/25/40.

Standards

- ✓ Flange: EN 1092-2.
- ✓ Coating: EN30677.
- ✓ Test EN12266-1.

Optional Features

- ✓ Flange drilling with BS or ANSI standard.
- ✓ GD8.8 Stainless steel, dacromet bolt.
- ✓ Various coating.
- ✓ Seal: NBR etc.

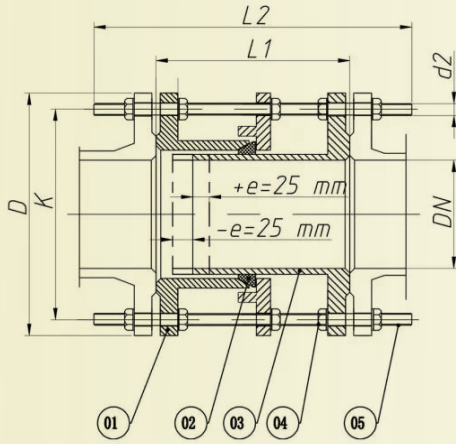

PART LIST & Dimensions

No.	Component	Standard Material	QTY
1	Short flange	GJS450-12	1
2	gasket	EPDM	1
3	Long flange	GJS450-12	1
4	nut	GD4.8	N
5	bolt	GD4.8	N

Nominal Diameter	PN10						PN16						PN25						
	DN	D	K	Bolt holes		L1	L2	D	K	Bolt holes		L1	L2	D	K	Bolt holes		L1	L2
				M	n*d					M	n*d					M	n*d		
DN40	150	110	M16	4*19	180	330	150	110	M16	4*19	180	330	150	110	M16	4*19	190	340	
DN50	165	125	M16	4*19	180	330	165	125	M16	4*19	180	330	165	125	M16	4*19	200	350	
DN65	185	145	M16	4*19	180	330	185	145	M16	4*19	180	330	185	145	M16	8*19	200	350	
DN80	200	160	M16	8*19	200	350	200	160	M16	8*19	200	350	200	160	M16	8*19	210	360	
DN100	220	180	M16	8*19	200	350	220	180	M16	8*19	200	350	235	190	M20	8*23	220	370	
DN125	250	210	M16	8*19	200	350	250	210	M16	8*19	200	350	270	220	M24	8*28	220	380	
DN150	285	240	M20	8*23	200	350	285	240	M20	8*23	200	350	300	250	M24	8*28	230	390	
DN200	340	295	M20	8*23	220	380	340	295	M20	12*23	220	380	360	310	M24	12*28	230	400	
DN250	400	350	M20	12*23	220	380	400	355	M24	12*28	230	400	425	370	M27	12*31	250	430	
DN300	455	400	M20	12*23	220	380	455	410	M24	12*28	250	420	485	430	M27	16*31	250	440	
DN350	505	460	M20	16*23	230	400	520	470	M24	16*28	260	440	555	490	M30	16*34	270	470	
DN400	565	515	M24	16*28	230	400	580	525	M27	16*31	270	460	620	550	M33	16*37	280	490	
DN450	615	565	M24	20*28	250	420	640	585	M27	20*31	270	460	670	600	M33	20*37	280	490	
DN500	670	620	M24	20*28	260	450	715	650	M30	20*34	280	490	730	660	M33	20*37	300	520	
DN600	780	725	M27	20*31	260	460	840	770	M33	20*37	300	520	845	770	M36	20*40	320	560	
DN700	895	840	M27	24*31	260	460	910	840	M33	24*37	300	520	960	875	M39	24*43	340	590	
DN800	1015	950	M30	24*34	290	500	1025	950	M36	24*40	320	550	1085	990	M45	24*49	360	630	
DN900	1115	1050	M30	28*34	290	500	1125	1050	M36	28*40	320	560	1185	1090	M45	29*49	380	660	
DN1000	1230	1160	M33	28*37	290	510	1255	1170	M39	28*43	340	600	1320	1210	M52	28*56	400	690	
DN1100	1340	1270	M33	32*37	300	530	1355	1270	M39	32*43	340	610	1420	1310	M52	32*56	420	720	
DN1200	1455	1380	M36	32*40	320	570	1485	1390	M45	32*49	360	650	1530	1420	M52	32*56	450	780	
DN1400	1675	1590	M39	36*43	360	620	1685	1590	M45	36*49	380	680	1755	1640	M56	36*62	480	800	
DN1600	1915	1820	M45	40*49	390	680	1930	1820	M52	40*56	400	720	1975	1860	M56	40*62	510	820	
DN1800	2115	2020	M45	44*49	400	700	2130	2020	M52	44*56	420	750	2195	2070	M64	44*70	540	860	
DN2000	2325	2230	M45	48*49	420	750	2345	2230	M56	48*62	440	800	2425	2300	M64	48*70	580	920	